



GHANA
CIVIL AVIATION AUTHORITY

ADVISORY CIRCULAR AC 14-005

AERODROME QUALITY DATA SYSTEM

GENERAL

Ghana Civil Aviation Authority (GCAA) Advisory Circulars from Aerodrome Safety and Standards (ASAS) contain information about standards, practices and procedures that the Authority has found to be an Acceptable Means of Compliance (AMC) with the associated Directives.

An AMC is not intended to be the only means of compliance with a Directive, and consideration will be given to other methods of compliance that may be presented to the Authority.

PURPOSE

This Advisory Circular (AC) provides information and guidance to aerodrome operators on the conduct of Aerodrome Quality Data System.

REFERENCE

The Advisory Circular relates specifically to the Aerodrome GCADs.

STATUS OF THIS AC

This is the first AC to be issued on this subject.

FOREWARD

This document provides guidance to Aerodrome Operators on aerodrome data collection and related information to forward to the Aerodrome Safety and Standards (ASAS) to be reviewed and made available for publication in the Aeronautical Information Publication (AIP). □

APPROVAL

Issue No: 01	Approved by:  _____ Director-General	Nov. 2018
--------------	---	-----------



TABLE OF CONTENTS

Table of Contents

1. INTRODUCTION	1
2. OBJECTIVE	1
3. APPLICABILITY	1
4. COMMON REFERENCE SYSTEMS	2
4.1. HORIZONTAL REFERENCE SYSTEM	2
4.2. VERTICAL REFERENCE SYSTEM	2
4.3. TEMPORAL REFERENCE SYSTEM	2
4.4. REFERENCE CODE	2
4.1 Table 1-1. Aerodrome reference code	4
5. AERODROME DATA	4
5.1. AERONAUTICAL DATA	4
5.2. AERODROME REFERENCE POINT	7
6. AERODROME AND RUNWAY ELEVATIONS	7
7. AERODROME REFERENCE TEMPERATURE	7
8. AERODROME DIMENSIONS AND RELATED INFORMATION	8
9. PRE-FLIGHT ALTIMETER CHECK LOCATION	9
10. DECLARED DISTANCES	10
11. CONDITION OF THE MOVEMENT AREA AND RELATED FACILITIES	10
12. COORDINATION BETWEEN AERONAUTICAL INFORMATION SERVICES AND AERODROME AUTHORITIES	11

1. INTRODUCTION

- 1.1.** The Director-General makes this Aerodrome Safety and Standards (ASAS) Advisory Circular (AC) in exercise of the powers conferred by the Ghana Civil Aviation Act, Act 678 (as amended by the Ghana Civil Aviation (Amendment) Act, 2016, Act 906).
- 1.2.** Responsibility for ensuring safety, regularity and efficiency of aircraft operations at aerodromes rests with contracting states to the Convention on International Civil Aviation. As such, contracting states such as Ghana, obliged to observe Articles 28 and 37 of the Convention and shall ensure aerodromes and aerodrome facilities, infrastructures and services provided are consistent with Standards and Recommended Practices (SARP) developed by ICAO.
- 1.3.** ICAO has mandated contracting states to promulgate regulatory requirements relating to aerodrome data. Besides that, States are also requested to have a quality system in place to verify the accuracy of aerodrome data to ensure compliance with the Directives, and to ensure that the accuracy, integrity and protection requirements for aeronautical data reported by the aerodrome operator are met throughout the data transfer process from the survey/origin to the next intended user.

2. OBJECTIVE

- 2.1.** This AC will ensure the production, publication and quality system of aerodrome data are in compliance with Standards and Recommended Practices (SARPs) specified in Annex 14 to the Convention on International Civil Aviation, and the Aerodrome GCADs.

3. APPLICABILITY

- 3.1** This AC is applicable and prescribes rules governing the management of aerodrome data at aerodromes, in any aerodrome of Ghana, intended for use by public transport aircraft. Aerodrome data for military aerodromes are not subject to this AC.
- 3.2** However, Private-owned aerodromes that are not open for use by public transport aircraft are also subject to the provisions of this Advisory Circular

4. COMMON REFERENCE SYSTEMS

4.1. HORIZONTAL REFERENCE SYSTEM

World Geodetic System — 1984 (WGS-84) shall be used as the horizontal (geodetic) reference system. Reported aeronautical geographical coordinates (indicating latitude and longitude) shall be expressed in terms of the WGS-84 geodetic reference datum.

Note. — Comprehensive guidance material concerning WGS-84 is contained in the ICAO World Geodetic System — 1984 (WGS-84) Manual (Doc 9674).

4.2. VERTICAL REFERENCE SYSTEM

Mean sea level (MSL) datum, which gives the relationship of gravity- related height (elevation) to a surface known as the geoid, shall be used as the vertical reference system.

Note 1.— The geoid globally most closely approximates MSL. It is defined as the equipotential surface in the gravity field of the Earth, which coincides with the undisturbed MSL extended continuously through the continents.

Note 2.— Gravity-related heights (elevations) are also referred to as orthometric heights while distances of points above the ellipsoid are referred to as ellipsoidal heights.

4.3. TEMPORAL REFERENCE SYSTEM

The Gregorian calendar and Coordinated Universal Time (UTC) shall be used as the temporal reference system. When a different temporal reference system is used, this shall be indicated in the General Aeronautical Information Publication (AIP); see ICAO Annex 15, Appendix 1.

4.4. REFERENCE CODE

The intent of the reference code is to provide a simple method for interrelating the numerous specifications concerning the characteristics of aerodromes so as to provide a series of aerodrome facilities that are suitable for the aeroplanes that are intended to operate at the aerodrome. The code is not intended to be used for determining runway length or pavement strength requirements. The code is composed of two elements, which are related to the aeroplane performance characteristics and dimensions. Element 1 is a number based on the aeroplane reference field length and element 2 is a letter based on the aeroplane wingspan and outer main gear wheel span. A particular specification is related to the more appropriate of the two elements of the code or to an appropriate combination of the two code elements. The code letter or number within an element selected for design purposes is related to the critical aeroplane characteristics for which the facility is provided. When applying ASAS ACs related to aerodrome design and operations, the aeroplanes which the aerodrome is intended to serve are first identified and then the two elements of the code

An aerodrome reference code — code number and letter — which is selected for aerodrome planning purposes shall be determined in accordance with the characteristics of the aeroplane for which an aerodrome facility is intended.

The aerodrome reference code numbers and letters shall have the meanings assigned to them in Table 1-1.

The code number for element 1 shall be determined from Table 1-1, column 1, selecting the code number corresponding to the highest value of the aeroplane reference field lengths of the aeroplanes for which the runway is intended.

Note. — The determination of the aeroplane reference field length is solely for the selection of a code number and is not intended to influence the actual runway length provided.

The code letter for element 2 shall be determined from Table 1-1, column 3, by selecting the code letter, which corresponds to the greatest wingspan, or the greatest outer main gear wheel, span, whichever gives the more demanding code letter of the aeroplanes for which the facility is intended.

Note.— Guidance to assist the appropriate authority in determining the aerodrome reference code is given in the ICAO Aerodrome Design Manual (Doc 9157), Parts 1 and 2.

4.1 Table 1-1. Aerodrome reference code

(see 16 to 18)

Code number (1)	Code element 1		Code element 2	
	Aeroplane reference field length (2)	Code letter (3)	Wingspan (4)	Outer main gear wheel span ^a (5)
1	Less than 800 m	A	Up to but not including 15 m	Up to but not including 4.5 m
2	800 m up to but not including 1 200 m	B	15 m up to but not including 24 m	4.5 m up to but not including 6 m
3	1 200 m up to but not including 1 800 m	C	24 m up to but not including 36 m	6 m up to but not including 9 m
4	1 800 m and over	D	36 m up to but not including 52 m	9 m up to but not including 14 m
		E	52 m up to but not including 65 m	9 m up to but not including 14 m
		F	65 m up to but not including 80 m	14 m up to but not including 16 m

a. Distance between the outside edges of the main gear wheels.

Note.— Guidance on planning for aeroplanes with wingspans greater than 80 m is given in the ICAO Aerodrome Design TP (Doc 9157), Parts 1 and 2.

5. AERODROME DATA

5.1. AERONAUTICAL DATA

Determination and reporting of aerodrome-related aeronautical data shall be in accordance with the accuracy and integrity requirements set forth in Tables A1-1 to A1-5 contained in Appendix 1 while taking into account the established quality system procedures. Accuracy requirements for aeronautical data are based upon a 95 per cent confidence level and in that respect, three types of positional data shall be identified: surveyed points (e.g. runway threshold), calculated points (mathematical calculations from the known surveyed points of points in space, fixes) and declared points (e.g. flight information region boundary points).

Note. — Specifications governing the quality system are given in ICAO Annex 15, Chapter 3.

Aerodrome mapping data should be made available to the aeronautical information services for aerodromes deemed relevant by States where safety and/or performance-based operations suggest possible benefits.

Note.— Aerodrome mapping databases related provisions are contained in ICAO Annex 15, Chapter 11.

Where made available in accordance with GCADs, the selection of the aerodrome mapping data features to be collected shall be made with consideration of the intended applications.

Note.— It is intended that the selection of the features to be collected match a defined operational need.

Where made available in accordance with GCADs, aerodrome mapping data shall comply with the accuracy and integrity requirements in Appendix 1.

Note.— Aerodrome mapping databases can be provided at one of two levels of quality — fine or medium. These levels and the corresponding numerical requirements are defined in RTCA Document DO-272B and European Organization for Civil Aviation Equipment (EUROCAE) Document ED-99C — User Requirements for Aerodrome Mapping Information.

Contracting States shall ensure that integrity of aeronautical data is maintained throughout the data process from survey/origin to the next intended user. Based on the applicable integrity classification, the validation and verification procedures shall:

- a) for routine data: avoid corruption throughout the processing of the data;
- b) for essential data: assure corruption does not occur at any stage of the entire process and may include additional processes as needed to address potential risks in the overall system architecture to further assure data integrity at this level; and
- c) for critical data: assure corruption does not occur at any stage of the entire process and include additional integrity assurance procedures to fully mitigate the effects of faults identified by thorough analysis of the overall system architecture as potential data integrity risks.

Note.— Guidance material in respect to the processing of aeronautical data and aeronautical information is contained in RTCA Document DO-200A and European Organization for Civil Aviation Equipment (EUROCAE) Document ED-76A — Standards for Processing Aeronautical Data.

Protection of electronic aeronautical data while stored or in transit shall be totally monitored by the cyclic redundancy check (CRC). To achieve protection of the integrity level of critical and essential aeronautical data as classified in 2.1.5, a 32- or 24-bit CRC algorithm shall apply, respectively.

To achieve protection of the integrity level of routine aeronautical data as classified in clause 23, a 16-bit CRC algorithm should apply.

Note. — Guidance material on the aeronautical data quality requirements (accuracy, resolution, integrity, protection and traceability) is contained in the World Geodetic System — 1984 (WGS-84) TP (Doc 9674). Supporting material in respect of the provisions of Appendix 1 related to accuracy and integrity of aeronautical data is contained in RTCA Document DO-201A and European Organization for Civil Aviation Equipment (EUROCAE) Document ED-77, entitled Industry Requirements for Aeronautical Information.

Geographical coordinates indicating latitude and longitude shall be determined and reported to the aeronautical information services authority in terms of the World Geodetic System — 1984 (WGS-84) geodetic reference datum, identifying those geographical coordinates which have been transformed into WGS-84 coordinates by mathematical means and whose accuracy of original field work does not meet the requirements in Appendix 1, Table A1-1.

The order of accuracy of the field work shall be such that the resulting operational navigation data for the phases of flight will be within the maximum deviations, with respect to an appropriate reference frame, as indicated in the tables contained in Appendix 1.

In addition to the elevation (referenced to mean sea level) of the specific surveyed ground positions at aerodromes, geoid undulation (referenced to the WGS-84 ellipsoid) for those positions as indicated in Appendix 1 shall be determined and reported to the aeronautical information services authority.

Note 1. — An appropriate reference frame is that which enables WGS-84 to be realized on a given aerodrome and with respect to which all coordinate data are related.

Note 2. — Specifications governing the publication of WGS-84 coordinates are given in ICAO Annex 4, Chapter 2 and ICAO Annex 15, Chapter 1.

5.2. AERODROME REFERENCE POINT

An aerodrome reference point shall be established for an aerodrome.

The aerodrome reference point shall be located near the initial or planned geometric centre of the aerodrome and shall normally remain where first established.

The position of the aerodrome reference point shall be measured and reported to the aeronautical information services authority in degrees, minutes and seconds.

6. AERODROME AND RUNWAY ELEVATIONS

The aerodrome elevation and geoid undulation at the aerodrome elevation position shall be measured to the accuracy of one-half metre or foot and reported to the aeronautical information services authority.

For an aerodrome used by international civil aviation for non-precision approaches, the elevation and geoid undulation of each threshold, the elevation of the runway end and any significant high and low intermediate points along the runway shall be measured to the accuracy of one-half metre or foot and reported to the aeronautical information services authority.

For precision approach runway, the elevation and geoid undulation of the threshold, the elevation of the runway end and the highest elevation of the touchdown zone shall be measured to the accuracy of one-quarter metre or foot and reported to the aeronautical information services authority.

Note. — Geoid undulation must be measured in accordance with the appropriate system of coordinates.

7. AERODROME REFERENCE TEMPERATURE

An aerodrome reference temperature shall be determined for an aerodrome in degrees Celsius.

The aerodrome reference temperature should be the monthly mean of the daily maximum temperatures for the hottest month of the year (the hottest month being that which has the highest monthly mean temperature). This temperature should be averaged over a period of years.

8. AERODROME DIMENSIONS AND RELATED INFORMATION

The following data shall be measured or described, as appropriate, for each facility provided on an aerodrome:

- a) runway — true bearing to one-hundredth of a degree, designation number, length, width, displaced threshold location to the nearest metre or foot, slope, surface type, type of runway and, for a precision approach runway category I, the existence of an obstacle free zone when provided;
- b) strip
runway end safety area
stopway } Length, width to the nearest
metre or foot, surface type;
- c) taxiway — designation, width, surface type;
- d) apron — surface type, aircraft stands;
- e) the boundaries of the air traffic control service;
- f) clearway — length to the nearest metre or foot, ground profile;
- g) visual aids for approach procedures, marking and lighting of runways, taxiways and aprons, other visual guidance and control aids on taxiways and aprons, including taxi-holding positions and stopbars, and location and type of visual docking guidance systems;
- h) location and radio frequency of any VOR aerodrome checkpoint;
- i) location and designation of standard taxi-routes; and
- j) distances to the nearest metre or foot of localizer and glide path elements comprising an instrument landing system (ILS) in relation to the associated runway extremities.

The geographical coordinates of each threshold shall be measured and reported to the aeronautical information services authority in degrees, minutes, seconds and hundredths of seconds.

The geographical coordinates of appropriate taxiway centre line points shall be measured and reported to the aeronautical information services authority in degrees, minutes, seconds and hundredths of seconds.

The geographical coordinates of each aircraft stand shall be measured and reported to the aeronautical information services authority in degrees, minutes, seconds and hundredths of seconds.

The geographical coordinates of obstacles in Area 2 (the part within the aerodrome boundary) and in Area 3 shall be measured and reported to the aeronautical information services authority in degrees, minutes, seconds and tenths of seconds. In addition, the top elevation, type, marking and lighting (if any) of obstacles shall be reported to the aeronautical information services authority.

Note 1.— See ICAO Annex 15, Appendix 8, for graphical illustrations of obstacle data collection surfaces and criteria used to identify obstacles in Areas 2 and 3.

Note 2.— Appendix 1 provides requirements for obstacle data determination in Areas 2 and 3.

Note 3.— Implementation of ICAO Annex 15, provisions 10.1.4 and 10.1.6, concerning the availability, as of 12 November 2015, of obstacle data according to Area 2 and Area 3 specifications would be facilitated by appropriate advance planning for the collection and processing of such data.

9. PRE-FLIGHT ALTIMETER CHECK LOCATION

One or more pre-flight altimeter check locations shall be established for an aerodrome.

A pre-flight check location should be located on an apron.

Note 1.— Locating a pre-flight altimeter check location on an apron enables an altimeter check to be made prior to obtaining taxi clearance and eliminates the need for stopping for that purpose after leaving the apron.

Note 2. — Normally an entire apron can serve as a satisfactory altimeter check location.

The elevation of a pre-flight altimeter check location shall be given as the average elevation, rounded to the nearest metre or foot, of the area on which it is located. The elevation of any portion of a pre-flight altimeter check location shall be within 3 m (10 ft) of the average elevation for that location.

10. DECLARED DISTANCES

The following distances shall be calculated to the nearest metre or foot for a runway intended for use by international commercial air transport:

- a) take-off run available;
- b) take-off distance available;
- c) accelerate-stop distance available; and d) landing distance available.

Note.— Guidance on calculation of declared distances is given in Attachment A.

11. CONDITION OF THE MOVEMENT AREA AND RELATED FACILITIES

Information on the condition of the movement area and the operational status of related facilities shall be provided to the appropriate aeronautical information services units, and similar information of operational significance to the air traffic services units, to enable those units to provide the necessary information to arriving and departing aircraft. The information shall be kept up to date and changes in conditions reported without delay.

Note. — Nature, format and conditions of the information to be provided are specified in ICAO Annex 15 and PANS-ATM (Doc 4444).

The condition of the movement area and the operational status of related facilities shall be monitored, and reports on matters of operational significance affecting aircraft and aerodrome operations shall be provided in order to take appropriate action, particularly in respect of the following:

- a) construction or maintenance work;
- b) rough or broken surfaces on a runway, a taxiway or an apron;
- c) water on a runway, a taxiway or an apron;
- d) other temporary hazards, including parked aircraft;
- e) failure or irregular operation of part or all of the aerodrome visual aids;
and
- f) failure of the normal or secondary power supply.

Note — Other contaminants may include mud, dust, sand, oil and rubber. ICAO Annex 6, Part I, Attachment C provides guidance on the description of runway surface conditions. Additional guidance is included in the ICAO Airport Services Manual (Doc 9137), Part 2.

To facilitate compliance with GCADs, inspections of the movement area shall be carried out each day at least once where the code number is 1 or 2 and at least twice where the code number is 3 or 4.

Note.— Guidance on carrying out daily inspections of the movement area is given in the ICAO Airport Services Manual (Doc 9137), Part 8 and in the ICAO Manual of Surface Movement Guidance and Control Systems (SMGCS) (Doc 9476).

Personnel assessing and reporting runway surface conditions required in clause 47 should be trained and competent to meet criteria set by GCAA.

Note.— Guidance on criteria is included in the ICAO Airport Services TP (Doc 9137), Part 8, Chapter 7.

12.COORDINATION BETWEEN AERONAUTICAL INFORMATION SERVICES AND AERODROME AUTHORITIES

To ensure that aeronautical information services units obtain information to enable them to provide up-to-date pre-flight information and to meet the need for in-flight information, arrangements shall be made between aeronautical information services and aerodrome authorities responsible for aerodrome services to report to the responsible aeronautical information services unit, with a minimum of delay:

- a) information on the status of certification of aerodromes and aerodrome conditions;
- b) the operational status of associated facilities, services and navigation aids within their area of responsibility;
- c) any other information considered to be of operational significance.

Before introducing changes to the air navigation system, due account shall be taken by the services responsible for such changes of the time needed by aeronautical information services for the preparation, production and issue of relevant material for promulgation. To ensure timely provision of the information to aeronautical information services, close coordination between those services concerned is therefore required.

Of a particular importance are changes to aeronautical information that affect charts and/or computer-based navigation systems which qualify to be notified by the aeronautical information Directive and control (AIRAC) system, as specified in Annex 15, Chapter 6 and Appendix 4. The predetermined, internationally agreed AIRAC effective dates in addition to 14 days postage time shall be observed by the responsible aerodrome services when submitting the raw information/data to aeronautical information services.

The aerodrome services responsible for the provision of raw aeronautical information/data to the aeronautical information services shall do that while taking into account accuracy and integrity requirements for aeronautical data as specified in Appendix 1 to this AC.

Note 1. — Specifications for the issue of NOTAM are contained in ICAO Annex 15, Chapter 5 and Appendices 6 and 2, respectively.

Note 2. — AIRAC information is distributed by the AIS at least 42 days in advance of the AIRAC effective dates with the objective of reaching recipients at least 28 days in advance of the effective date.

Note 3.— The schedule of the predetermined internationally agreed AIRAC common effective dates at intervals of 28 days and guidance for the AIRAC use are contained in the ICAO Aeronautical Information Services Manual (Doc 8126, Chapter 2).

The Appendices to this AC shall be taken, construed, read and be part of this AC.

APPENDIX 1. AERONAUTICAL DATA QUALITY REQUIREMENTS

Table A1-1. Latitude and longitude

Latitude and longitude	Accuracy Data type	Integrity Classification
Aerodrome reference point	30 m surveyed/calculated	routine
Nav aids located at the aerodrome	3 m surveyed	essential
Obstacles in Area 3	0.5 m surveyed	essential
Obstacles in Area 2 (the part within the aerodrome boundary)	5 m surveyed	essential
Runway thresholds	1 m surveyed	critical
Runway end (flight path alignment point)	1 m surveyed	critical
Runway centre line points	1 m surveyed	critical
Runway-holding position	0.5 m surveyed	critical
Taxiway centre line/parking guidance line points	0.5 m surveyed	essential
Taxiway intersection marking line	0.5 m surveyed	essential
Exit guidance line	0.5 m surveyed	essential
Apron boundaries (polygon)	1 m surveyed	routine
De-icing/anti-icing facility (polygon)	1 m surveyed	routine
Aircraft stand points/INS checkpoints	0.5 m surveyed	routine

Note 1.— See Annex 15, Appendix 8, for graphical illustrations of obstacle data collection surfaces and criteria used to identify obstacles in the defined areas.

Note 2.— Implementation of Annex 15, provisions 10.1.4 and 10.1.6, concerning the availability, as of 12 November 2015, of obstacle data according to Area 2 and Area 3 specifications would be facilitated by appropriate advance planning for the collection and processing of such data.

ATTACHMENT A – CALCULATION OF DECLARED DISTANCES

1. The declared distances to be calculated for each runway direction comprise: the take-off run available (TORA), take-off distance available (TODA), accelerate-stop distance available (ASDA), and landing distance available (LDA).
2. Where a runway is not provided with a stopway or clearway and the threshold is located at the extremity of the runway, the four declared distances should normally be equal to the length of the runway, as shown in Figure A-1 (A).
3. Where a runway is provided with a clearway (CWY), then the TODA will include the length of clearway, as shown in Figure A-1 (B).
4. Where a runway is provided with a stopway (SWY), then the ASDA will include the length of stopway, as shown in Figure A-1 (C).
5. Where a runway has a displaced threshold, then the LDA will be reduced by the distance the threshold is displaced, as shown in Figure A-1 (D). A displaced threshold affects only the LDA for approaches made to that threshold; all declared distances for operations in the reciprocal direction are unaffected.
6. Figures A-1 (B) through A-1 (D) illustrate a runway provided with a clearway or a stopway or having a displaced threshold. Where more than one of these features exist, then more than one of the declared distances will be modified — but the modification will follow the same principle illustrated. An example showing a situation where all these features exist is shown in Figure A-1 (E).
7. A suggested format for providing information on declared distances is given in Figure A-1 (F). If a runway direction cannot be used for take-off or landing, or both, because it is operationally forbidden, then this should be declared and the words “not usable” or “NU” entered.

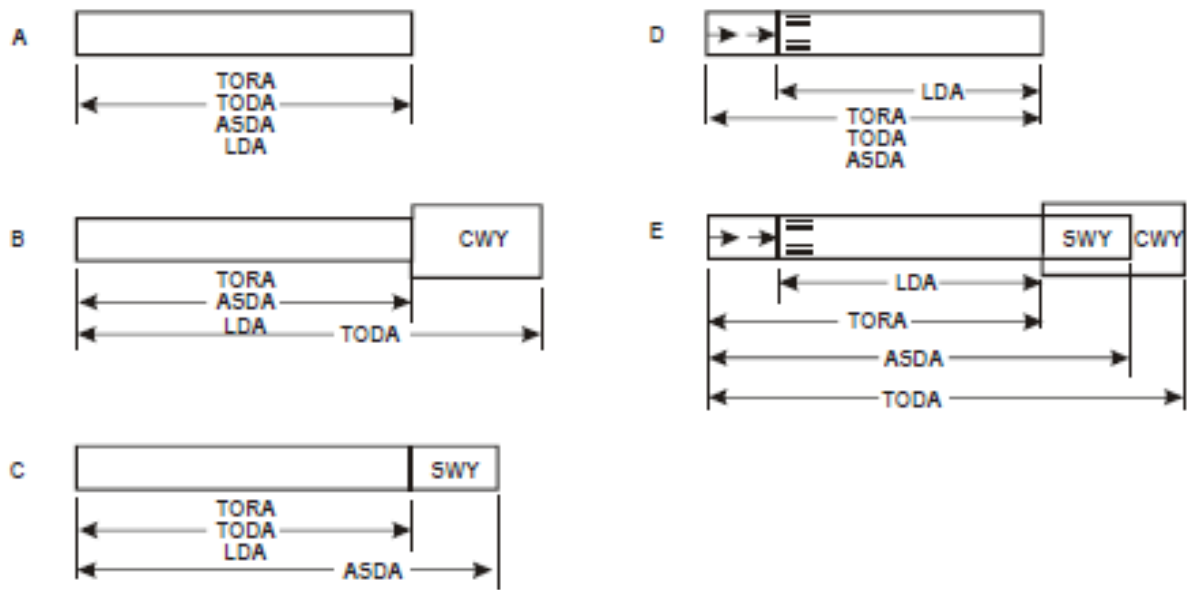

Note.— All declared distances are illustrated for operations from left to right.

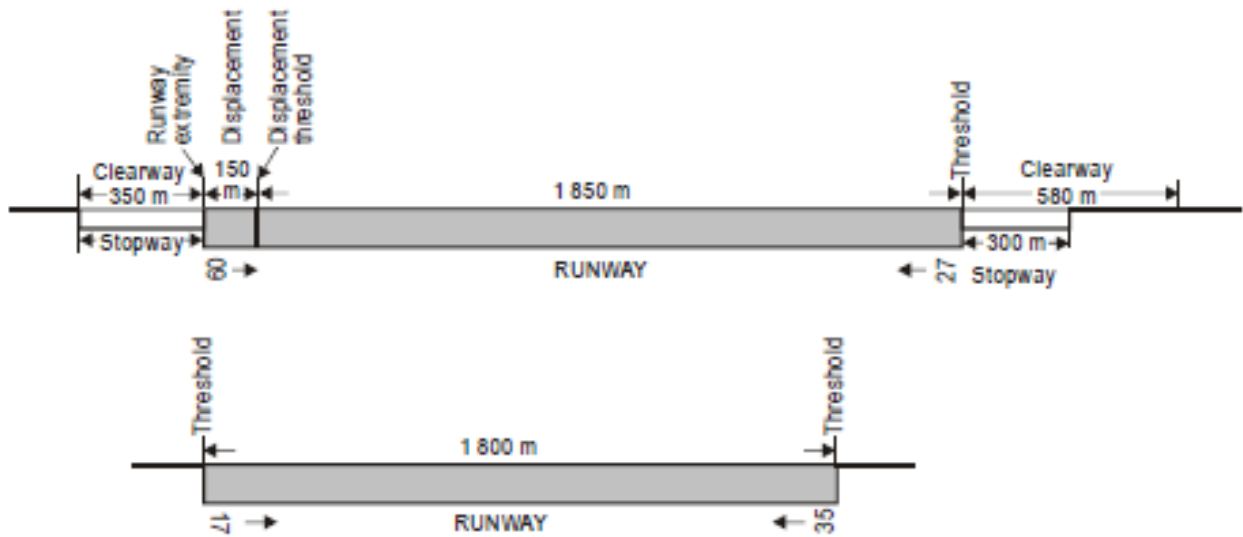

F

RUNWAY	TORA m	ASDA m	TODA m	LDA m
09	2 000	2 300	2 580	1 850
27	2 000	2 350	2 350	2 000
17	NU	NU	NU	1 800
35	1 800	1 800	1 800	NU

Figure A-1 : Illustration of declared distances