

# **GHANA CIVIL AVIATION AUTHORITY**



## **GUIDANCE ON LIGHTING AND MARKING OF OBSTACLES**

## 1.0 PURPOSE

This specification sets forth the Ghana Civil Aviation Authority's requirements for various obstruction lighting systems/equipment and marking/painting used to increase conspicuity of structures to permit early obstruction recognition by pilots. Lighting standards in this circular are the minimum necessary for aviation safety. The lights should be positioned to ensure that a pilot has an unobstructed view of at least one light at each level.

*Air accidents* cause immense loss to human life and property. Accidents can however be avoided by little precautions. Among various measures in place, visual aids are of immense importance in creating safer skies.

Structures such as crane chimneys, tall buildings, extensive buildings, television, radio and telecommunications towers, flares stacks, electricity transmission lines, bridges, wind turbines and military radar require lighting and marking.

## 1.1 LIGHTING

High-rising structures and other geographical obstructions are hazardous to aviation safety because of their heights and location. Due to the numerous threat pose to airplanes in poor visibility, high-rising structures should be illuminated with obstruction lights according to ICAO standards. Table 1 provides ICAO classification of obstruction lighting and compatible light units (FAA classification). Characteristics/description of each light unit is also provided in table 2.

**Obstruction light**, defined as light indicating the presence of an object which is dangerous to an aircraft in flight. All tall structures must be lit at the topmost point of the structure and the light units must show at all radials throughout the omnidirectional 360 degrees. Obstruction light combinations and levels to be installed on structures as given in table 3.

### 1.1.1 Placement Factors

The lights should be positioned to ensure that a pilot has an unobstructed view of at least one light at each level.

In the case of a extensive/solid structure such as building, the top lights shall be so arranged to indicate the points or edges of the structure, and lights should be visible when approaching the structure from any direction (**see figure 2 (b)**). In the case of a chimney or other structure of like function, the top lights should be placed sufficiently below the top of the structure (**see chimney in figure 1(b)**) so as to minimize contamination by smoke, etc.

The overall height of the structure including all appurtenances such as rods, antennas, obstruction lights, etc., above ground level (AGL) determines the number of light levels. The light levels may be adjusted slightly, but not to exceed 10 feet (3m), when necessary to accommodate guy wires and personnel who replace or repair light fixtures.

For tall structures above 45m, there is the need for additional intermediate lights which should be spaced as equal as practicable between the top lights and ground level. At middle levels, obstruction lights should be displayed for each 45 m or fraction thereof. The position of these lights on the vertical plane should be equidistant between the top lights and the ground level as the shape and type of obstruction will permit.

Non Flashing obstruction red lights should be mounted at the top of a high rise building. One such light should be displayed at the outside corner on each level with the remaining lights evenly spaced between the corner lights.

The spacing between lights at the same level or different level should not exceed 45m. **See figure 2 (a)** and use the simple formula to determine:

- (a). Number of levels required as structure height increases;
- (b). Determine the spacing between lights up to the top; and
- (c). The number of lights required at a level edge.

Obstruction lights are broadly divided into three types of (low, medium and high intensities). Most manufacturers of obstacle lights provide lighting specifications meeting FAA or ICAO type ratings (see tables 1 & 2).

The selection of a particular type of lighting depends on the height and the nature of the structure. Tables 1-3 provide types of obstacle lighting and their applications.

## 1.2 OPERATIONS AND MAINTENANCE OF OBSTRUCTION LIGHTINGS

**“A dark tower for whatever reason will attract a fine from the Ghana Civil Aviation Authority. Light units must be maintained and lit in poor visibility conditions at all times”**

Lighting should be auto operational from dusk to dawn by a photocell or light controller (photo sensing device) and an optional transfer relay that powers the standby light if main light fails. There should be a tower light monitoring systems to alert (See **section 1.2.1**).

- (a). a failed day/night photocell
- (b). an open tower lighting circuit breaker or utility power failure

Lights are to be operational at nights and in low visibility weather conditions. The intensity variations/step changing for the types of lights under various weather visibility conditions are given in **section 1.2.2**.

### 1.2.1 Monitoring

Obstruction lighting systems should be closely monitored by visual or automatic means. It is extremely important to visually inspect obstruction lighting in all operating intensities at least once every 24 hours on **systems without automatic monitoring**.

Each light unit must be monitored for FLASH/FAIL status. FAIL status is defined as either of the following conditions:

- unit misses four or more consecutive flashes;
- unit flashes at wrong intensity step during day operation.
- outage of any lamp

Monitoring must be fail/safe (i.e., active signals for FLASH and absence of signals for FAIL). There must be a provision to permit connection to a remote alarm device, (supplied by others or as an option), to indicate the system and individual light unit FLASH/FAIL status.

In the event a structure is not readily accessible for visual observation, a properly maintained automatic monitor should be used. This monitor should be designed to register the malfunction of any light on the obstruction regardless of its position or color.

When using remote monitoring devices, the communication status and operational status of the system should be confirmed at least once every 24 hours. The monitor (aural or visual) should be located in an area generally occupied by responsible personnel. In some cases, this may require a remote monitor in an attended location. For each structure, a log should be maintained in which daily operations status of the lighting system is recorded. Beacon lenses should be replaced if serious cracks, crazing, dirt build up, etc., has occurred.

**1.2.2 Intensity Step Changing**

Obstruction lights should be operated by satisfactory photocell (control device) adjusted so that the lights will be turned on when the sky illuminance reaching a vertical surface falls below a level of 60 foot-candles (645.8 lux) but before reaching a level of 35 foot-candles (367.7 lux).

The control device should turn the lights off when the northern sky illuminance rises to a level of not more than 60 foot-candles (645.8 lux). The lights may also remain on continuously.

The Intensity Step changing given in Table 2 will depend on the ambient light intensity. The **ambient** intensity is the light available in the environment. There is no particular direction to the light source.

In contrast, the **light** intensity is the effect of a simulated light source placed at the viewer's line of sight. The **light** intensity affects the intensity of the highlights and shadows, while the **ambient** intensity affects the brightness of the objects in the overall scene. The following is the ambient background lighting conditions:

Day	:	>500 candles/m <sup>2</sup>
Twilight	:	=50 – 500 candles/m <sup>2</sup>
Night	:	< 50 candles/m <sup>2</sup>

**(a) White Obstruction Lights**

Steady white light must not be used for obstruction lighting purposes. White obstruction lights shall automatically change intensity steps when the ambient light changes as follows:

- (i). From **day to twilight** intensity when the illumination is 60-35 foot-candles
- (ii). From **twilight to night** intensity when the illumination decreases 5-2 foot-candles.
- (iii). From **night to twilight** intensity when the illumination increases 5-2 foot-candles.
- (iv). From **twilight to day** intensity when the illumination increases above 60-35 foot-candles.

**Note:**

$L [lx] = 2.5 \times 2^{EV}$  (exposure value)  
 1 foot-candle = about 10.764 lux;  
 EV 1 approx. equals to 0.46 foot candle or 5 lux.

**(b) Red Obstruction Lights**

If automatic control is utilized, the light unit shall turn on when the ambient light decreases to not less than 35 foot-candles and turn off when the ambient light increases to not more than 60 foot-candles. Single L-810 light units are controlled in a manner compatible with the particular installation.

**(c) Dual Obstruction Lighting System**

White obstruction lights shall turn off and red obstruction lights shall turn on when ambient light changes from twilight to night when the illumination is 5-2 foot-candles.

Red obstruction lights shall turn off and white obstruction lights shall turn on when ambient light changes from night to twilight when the illumination increases 2-5 foot-candles.

**1.2.3 Light Units**

The light unit must be designed for easy servicing and lamp (or flashtube) replacement. Each unit must be an independent unit and must flash at the specified intensity where applicable, or at its highest intensity when control signals are absent.

For safe maintenance purposes, the installation of double lights units at each required point is encouraged for one to provide continuous service when preparations are being done to replace a burnt out light. Again, **a dark tower for whatever reason will attract a fine from the Ghana Civil Aviation Authority.**

**2.0 MARKING OF STRUCTURES**

Low flying aircraft's, in spite of the modern navigational facilities on board, need prominent obstruction markings in their flight paths. These markings should be visible enough to attract the pilot's attention.

Obstructions are generally marked using a combination of two of three basic colours.

- (a). The structure should be marked/painted to show alternating equal bands of **Aviation Orange/Red and White**.
- (b). Coloured patterns used to mark objects should consist of rectangles of not less than 1.5 m and not more than 3 m on a side, the corners being of the darker colour This applies to skeletal types of structure as well. The bands should be perpendicular to the longest dimension of the structure (**See Figure 1(a) & (b)**).
- (c). The width of each band depends upon the total height of the particular structure. **Table 4** provides the bandwidth applicable to the differing structure heights.

**CALCULATION OF WIDTH OF BAND**

Example (A): Structure 60m high.

Width of Band – since structure is greater than 1.5m but not exceeding 210m, Band width is 1/7 of 60m = 8.75m (**See Table 4**)

**Table 1 – Classification of Obstruction Lighting**

Obstruction Lights	ICAO Type			
	A	B	C	D
<p><b>Low Intensity</b></p> <p>Less extensive objects height &lt; 45m.</p>	<p><b>Steady Red</b> lights (for fixed obstacle)</p> <p><u>Compatible Light Units</u></p> <p>L-810</p> <p><u>Intensity Step Changing</u></p> <p>Night ≥ 10 candelas</p>	<p><b>Steady Red</b> lights (for fixed obstacle)</p> <p><u>Compatible Light Units</u></p> <p>L-810</p> <p><u>Intensity Step Changing</u></p> <p>Night ≥ 32 candelas</p>	<p><b>Flashing Yellow/Blue</b> lights (60-90 fpm) (for mobile obstacle)</p> <p><u>Compatible Light Units</u></p> <p><u>Intensity Step Changing</u></p> <p>≥ 40 candelas</p>	<p><b>Flashing Yellow</b> lights (60-90fpm) ( for “Follow-me” Vehicles)</p> <p><u>Compatible Light Units</u></p> <p><u>Intensity Step Changing</u></p> <p>≥ 200 candelas</p>
<p><b>Medium Intensity</b></p> <p>Extensive objects or height &gt; 45m.</p>	<p><b>Flashing White</b> lights (20-60 fpm)</p> <p><u>Compatible Light Units</u></p> <p>L-865; 40FPM L-866; 60FPM</p> <p><u>Intensity Step Changing</u></p> <p>Day ≥ 20,000 cd Twilight ≥ 20,000 cd Night ≥ 2000 cd</p>	<p><b>Flashing Red</b> lights (20-60fpm)</p> <p><u>Compatible Light Units</u></p> <p>L-864; 20-40 FPM L-885; 60FPM</p> <p><u>Intensity Step Changing</u></p> <p>Night ≥ 2000 candelas</p>	<p><b>Steady Red</b> lights</p> <p><u>Compatible Light Units</u></p> <p>L-810</p> <p><u>Intensity Step Changing</u></p> <p>Night ≥ 2000 candelas</p>	
<p><b>High Intensity</b></p> <p>(Object height &gt; 150m)</p>	<p><b>Flashing White</b> lights (40-60 fpm)</p> <p><u>Compatible Light Units</u></p> <p>L-856; 40FPM L-857; 60FPM</p> <p><u>Intensity Step Changing</u></p> <p>Day ≥ 200,000 cd Twilight ≥ 20,000 cd Night ≥ 2,000 cd</p>			

FPM – Flashes per Minute

**Table 2 – Types of Light Units**

Type	Description	Intensities Step Requirements
L-810	Steady-burning Red Obstruction Light	Intensity - 2,000 ± 25%
L-856	High Intensity Flashing White Obstruction Light (40FPM)	Day - 200,000 ± 25%
		Twilight - 20,000 ± 25%
		Night - 2,000 ± 25%
L-857	High Intensity Flashing White Obstruction Light (60 FPM)	Day - 200,000 ± 25%
		Twilight - 20,000 ± 25%
		Night - 2,000 ± 25%
L-864	Flashing Red Obstruction Light (20-40 FPM)	Single Intensity - 2,000 ± 25%
L-865	Medium Intensity Flashing White Obstruction Light (40 FPM)	Day/ Twilight - 20,000 ± 25%
		Night - 2,000 ± 25%
L-866	Medium Intensity Flashing White Obstruction Light (60 FPM)	Day/Twilight - 20,000 ± 25%
		Night - 2,000 ± 25%
L-885	Flashing Red Obstruction Light ( 60 FPM)	Single Intensity - 2,000 ± 25%
FPM = Flashes Per Minute		

**Note:**

The requirements for L-866 are the same as the L-865 light unit, except the flash rate.

The requirements for L-885 are the same as the L-864 light unit, except the flash rate.

**Table 3 – Structure Height & Light Units Application/Combinations**

HEIGHT OF STRUCTURE ABOVE SURROUNDING GROUND	MARKED	OBSTRUCTION LIGHTING
<45m	YES	At night/low visibility conditions <b>Low Intensity Type-A/B -</b>
>45m<105m	YES	At night/low visibility conditions <b>Low Intensity Type-A/B - (Lower level)</b> & <b>Medium Intensity Light Type-B/C - (Upper level)</b>
>45m<105m	YES	At night/low visibility conditions <b>Medium Intensity Light Type-A</b>
>105m <150m	YES	Night/low visibility conditions <b>Low Intensity Obstruction Type-A/B - (Lower level)</b> & <b>Medium Intensity Light Type-B/C - (Upper level)</b>
>105m <150m	YES	At Night/low visibility conditions <b>Medium Intensity Light Type-A</b>
>150m	YES	At Night/low visibility conditions <b>Low Intensity Obstruction Type-A/B - (At multiple lower levels)</b> & <b>Medium Intensity Light Type-B/C - (Upper level)</b>
>150m	YES	Day & Night/low visibility conditions <b>Medium Intensity Light Type-A - (At multiple levels)</b>
>150m	YES	Day & Night/low visibility conditions <b>High Intensity Obstruction Light Type-A - (At multiple levels)</b>

Table 4 - Marking band widths

---



---

**Longest Dimension**

<b>Greater than</b>	<b>Not exceeding</b>	<b>Band Width</b>
1.5m	210m	1/7 of longest dimension
210m	270m	1/9 of longest dimension
270	330m	1/11 of longest dimension
330m	390m	1/13 of longest dimension
390m	450m	1/15 of longest dimension
450m	510m	1/17 of longest dimension
510m	570m	1/19 of longest dimension
570m	630m	1/21 of longest dimension

---



---

The Aerodrome Safety & Standards Section of the Safety Regulations Dept., Ghana Civil Aviation Authority should be contacted for further clarification.

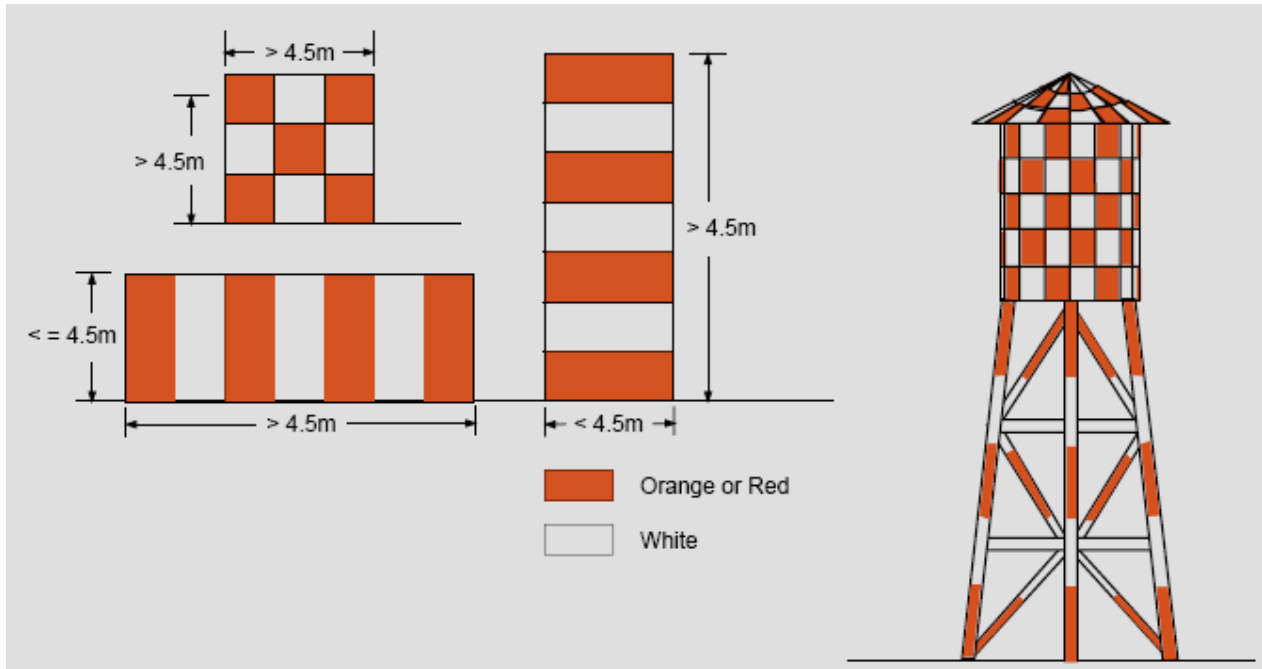

Figure 1 (a) – Basic Marking Patterns

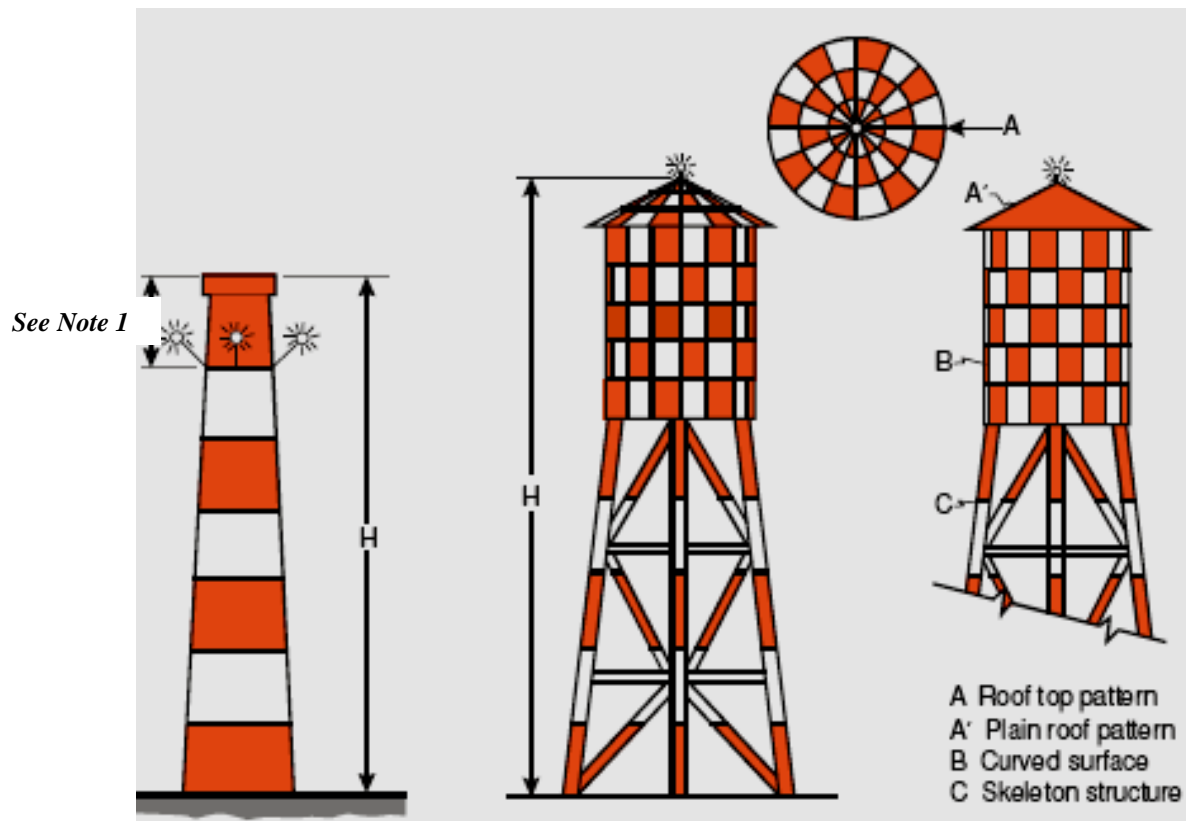
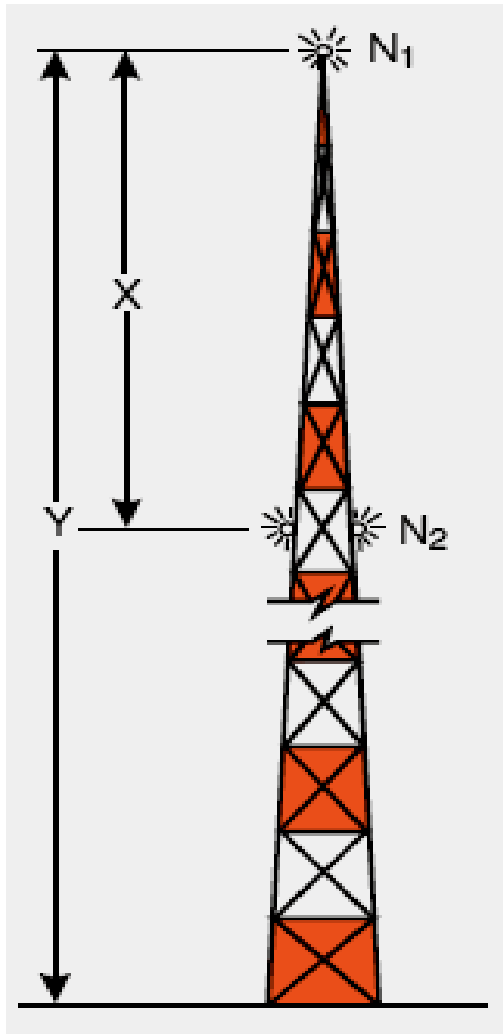

Figure 1(b) – Marking and lighting of tall structures

*Note. 1 — In the case of chimney or other structure of like function, the top lights should be placed sufficiently below the top so as to minimize contamination by smoke etc..*

*Note. 2 — H is less than 45 m for the examples shown above. For greater heights intermediate lights must be added as shown Figure 2 (a).*



Number of obstruction lights to be placed on tall structures can be calculated by the following formula:

$$\text{Number of levels of lights} = N = \frac{Y \text{ (metres)}}{45}$$

$$\text{Light spacing} = X = \frac{Y}{N} \leq 45\text{m}$$

Where; Y is the height of the Obstruction.

*Note - There should be at least 45 meter gap between two obstruction lights installed on tall structures.*

**Figure 2 (a) – Lighting of tall structures (No. and Spacing)**

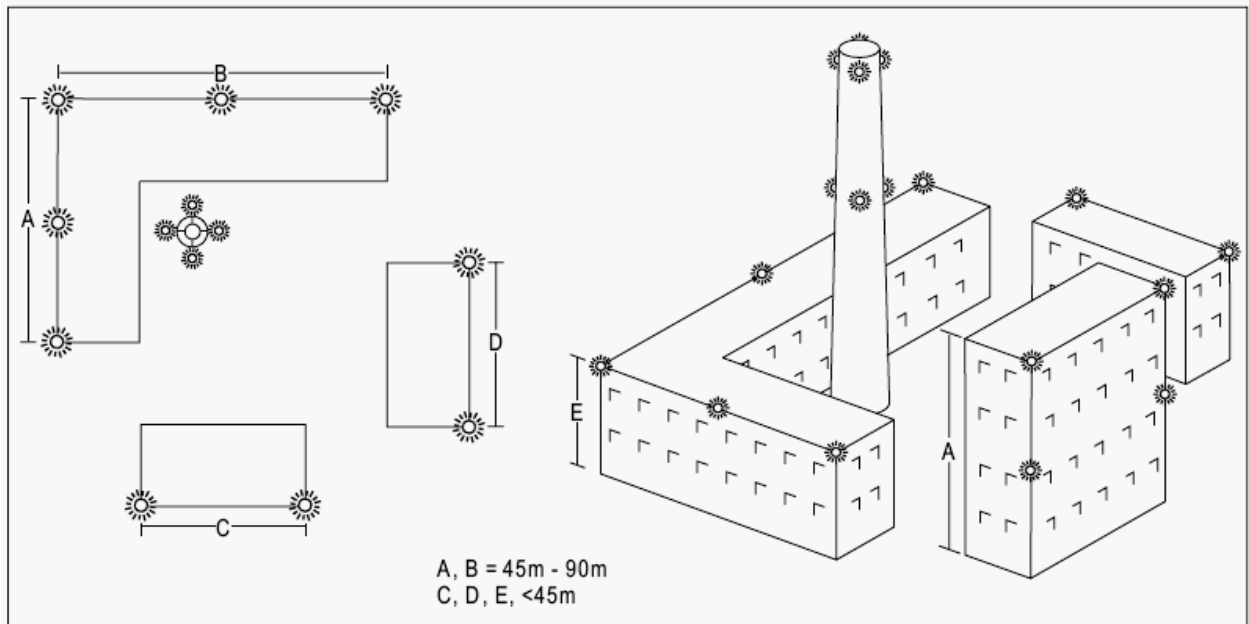
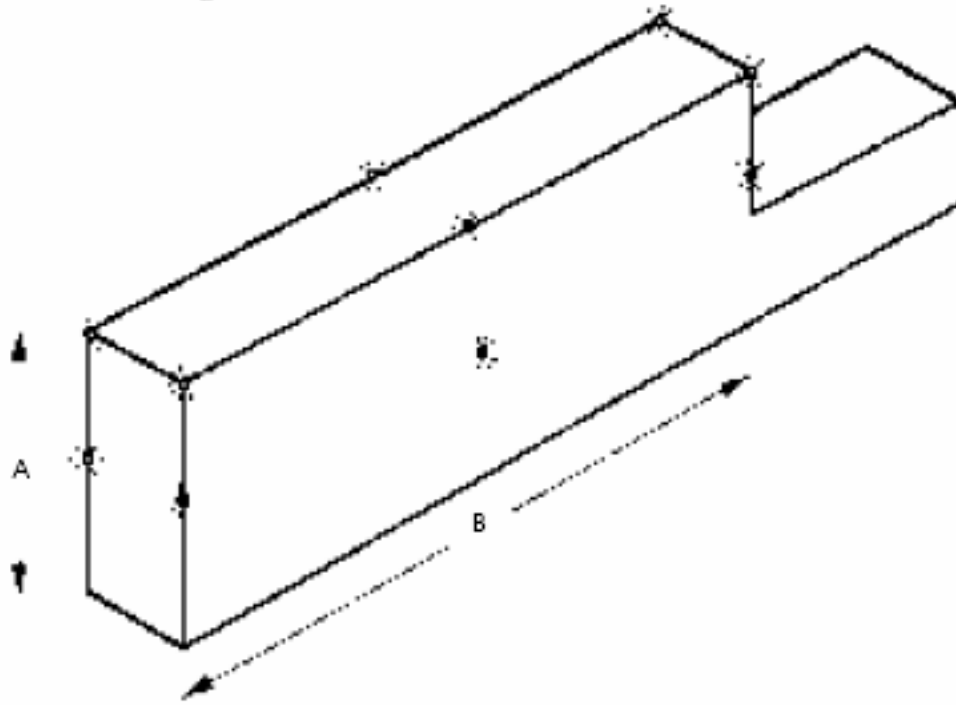

Figure 2 (b) – Lighting of buildings